

FIBREROLL S



rullari®

STYLISH SECURITY

Bolton Gate Company

SMOKE TIGHT, FIRE RESISTING ROLLING CURTAIN

Bolton Gate Company, the acknowledged leader in the field of rolling fire door technology, introduces an enhanced design of fire curtain to provide not only two-hour fire integrity between fire compartments but also providing a smoke tight seal all in accordance with EN1634-3. Additionally, the integrated reflective coating which reduces radiated heat to such a large extent the curtain also meets the requirements for a rating of up to EW60.

PERFORMANCE CHARACTERISTICS:

Sa Smoketight accreditation. Fire resistance to E30, E60, or E120 classifications Radiated heat reduction of 15 kW/m² to EW30 or EW60 classifications.

ACCREDITATIONS:

Tested to EN1634-1 and EN1634-3 all in accordance with EN 13501-2, EN15269-11. These active fire curtains are CE marked all in keeping with BS EN 13241:2003+A2:2016 and EN 16034.

APPLICATIONS INCLUDE:

Retail Malls; Offices; Receptions / Foyers; Lift Lobbies / Lift Doors; Open-plan private residencies.

STANDARD SPECIFICATION:

Operation

Electric operation is by means of a tubular motor suitable for connection to a 230-volt nominal single-phase supply with gravity failsafe closure in a fire condition. A control panel is provided complying with EN 14637 incorporating operating buttons on the lid and the facility for connection of a normally closed volt free contact from the Client's fire alarm system with a low-level emergency close / reset button. A battery is included to prevent unwanted closing of the curtain in case of power failure.

The curtain will automatically descend upon receipt of the fire signal.

If the curtain system is to be used on an escape route, only local heat detection can be used. This can be accommodated by our operating controls – see options below.

Curtain

Specially reinforced and coated fibre-glass material 0.7mm thick which is designed to withstand temperatures in excess of 1000 degrees C.

Bottom Rail

A steel bottom rail is attached to provide rigidity and act as a weight to assist closure.

Guides

Manufactured from galvanised steel and formed into a slimline profile which is prepared for bolting to the opening structure. An integral sealing arrangement is incorporated to prevent the passage of smoke around the edges of the curtain.

Roller

The roller comprises a 101 mm diameter steel tube in which the tubular motor is fitted at one end and steel shafts / discs at the other.

Endplates

Galvanised steel endplates are provided with integrated angles to simplify installation.

Coil Casing

The roller is covered by a galvanised steel casing which also acts as a fire seal at the head complete with an integrated smoke baffle.

Finish

The curtain is grey / silver with the casing, side guides and bottom rail polyester powder coated in RAL 9006 or 9010.

WEIGHT

Varies with opening size but approximately 45kg/m².

OPTIONS

- Sounder beacon during closing.
- Voice warning during closing.
- Emergency retract via UPS and push button on 1 or 2 sides
- Two stage or delayed descent.
- Obstruction warning using light curtain or photocell with delayed timer and sounder.
- Side guides, bottom rail and coil casing supplied with polyester powder coated finish to alternative RAL colour from standard range.
- Local heat detector.
- ES200 and EWS200 option also available.

 **KOKEMA_{OY}**

Kakkulaistentie 5, 32800 Kokemäki

Tel. +358 10 326 3840

info@kokema.fi | www.kokema.fi

BOX DETAIL

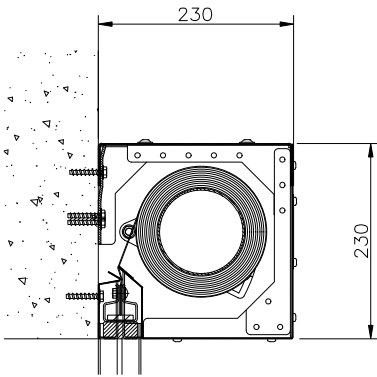

FACE FIXED

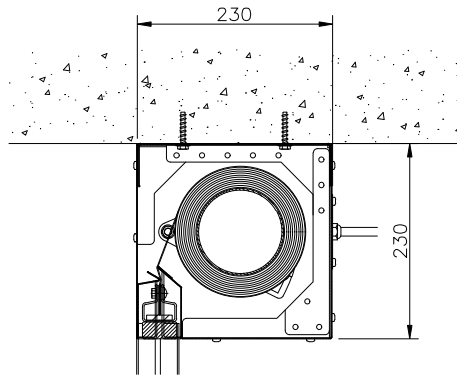

SOFFIT FIXED

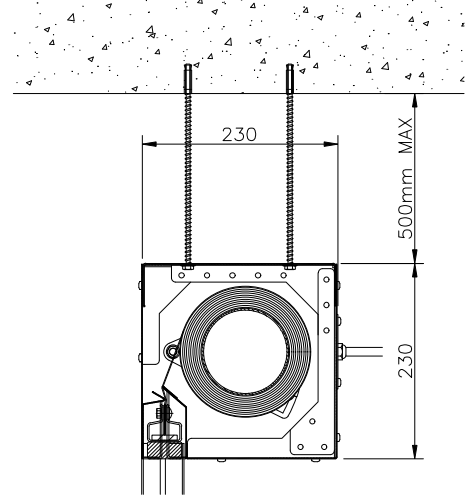

SUSPENDED

'E Sa' Rated Curtains	Max Clear Width	Max Clear Height	Guide Size 'A'
E60 Sa	5794mm	3970mm	100mm
E60 Sa	6360mm	3970mm	120mm
E90 Sa	5000mm	3970mm	100mm
E90 Sa	6360mm	3970mm	120mm
E120 Sa	5000mm	3650mm	100mm

'EW Sa' Rated Curtains	Max Clear Width	Max Clear Height	Guide Size 'A'
EW60 Sa	5794mm	3970mm	100mm
EW60 Sa	6360mm	3970mm	120mm

JAMB / GUIDE DETAIL

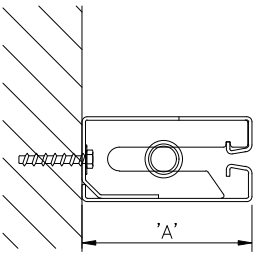

FIXED BETWEEN

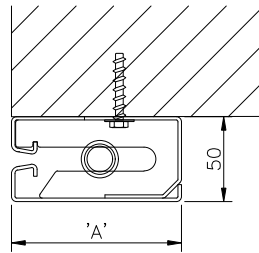

FACE FIXED

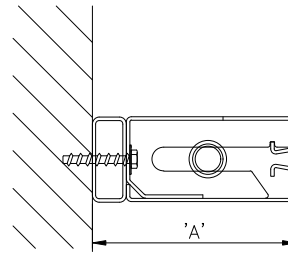

120mm FIXED BETWEEN

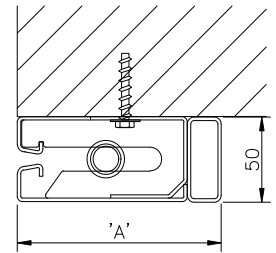

120mm FACE FIXED